



## Lock Synergy Access Control Series

### LSEM-600-W

#### 600lb/272kg Weatherized Electromagnetic Lock

A 600 pound holding force, UL rated weather resistant stainless steel electromagnetic lock designed for medium security outdoor applications. where perimeter door security and access control is required. Ideal for outdoor perimeter door or gate access control points, this lock can be used with wood, metal or glass doors. This lock is the natural choice for applications where elements of nature is a factor.

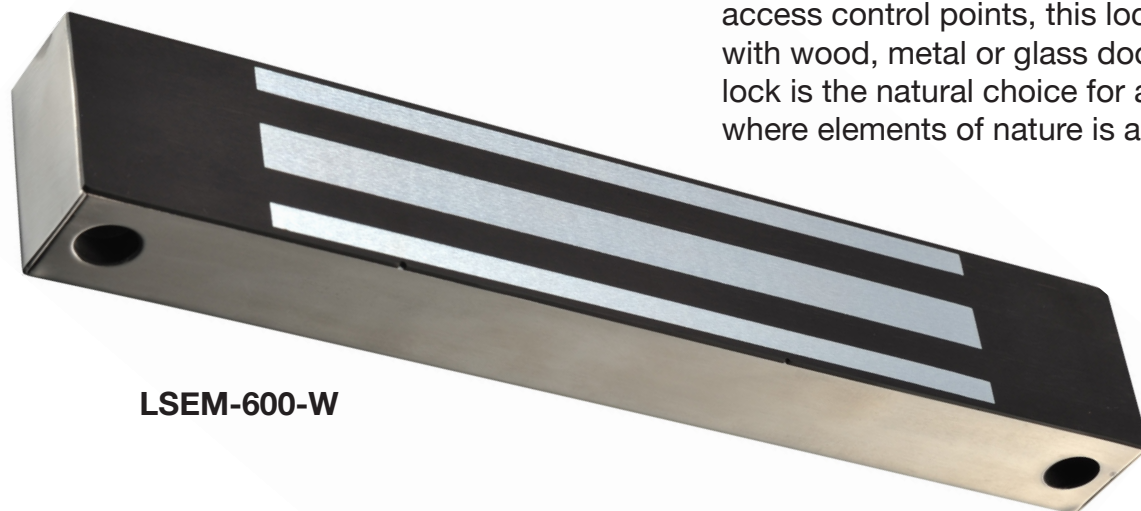

LSEM-600-W

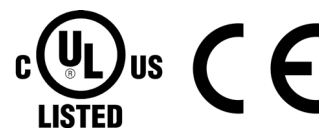

#### Features

- Peel and Stick paper template for easy installation and time savings
- 630 brushed stainless steel finish
- 12/24VDC Field Selectable Input
- Voltage spike protection
- No Residual Magnetism
- Epoxy sealed electronics for outdoor use
- Stainless Steel nuts and screws
- Built-in jacketed conductor for easy wiring (side exit)

#### Benefits

- Great for outdoor applications
- No mounting bracket required
- Long operational life duration



## Specifications

---

- Holding Force:  
600lbs/ 272kg
- Weight: 2kg
- Jacketed Conductor exit on side
- Voltage: 12/24VDC
- Power Consumption:  
12V/480mA, 24V/240mA
- 6in/15cm Conductor Cable
- Magnetic Lock Dimensions:  
22.5cm (8.875") x 4cm (1.5") x 2.6cm (1")
- Armature Dimensions:  
18cm (7") x 3.8cm (1.5") x 1.25cm (.5")

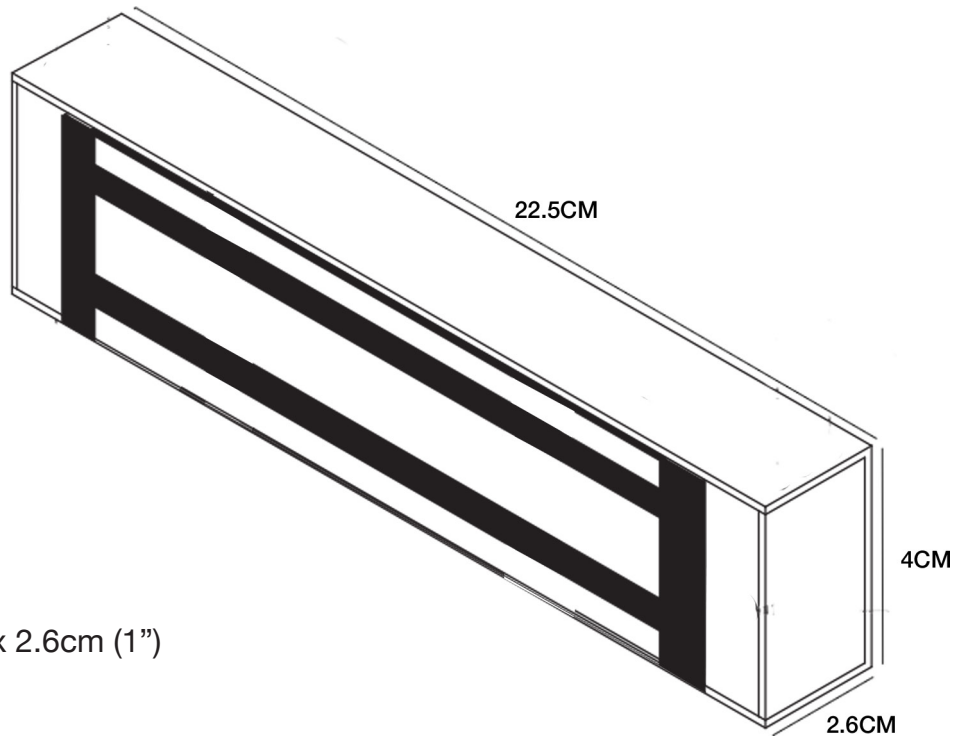

## Certifications

---



EN 55022, EN 50130-4 /1996,  
EN 61000-4-2 /-3 /-4 /-6



UL10C: Auxiliary Locks  
GWXT.R26707

## Warranty

---

3 Year Limited Manufacturer Warranty